

## Mercedes-Benz Unimog U 300 Euro 5

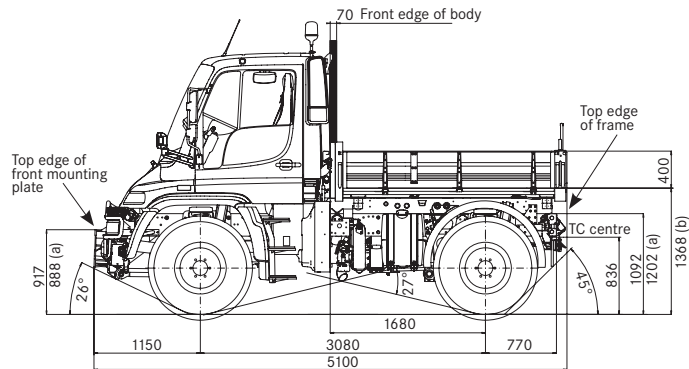

Wheelbase 3,080 mm (model variant 405.101)

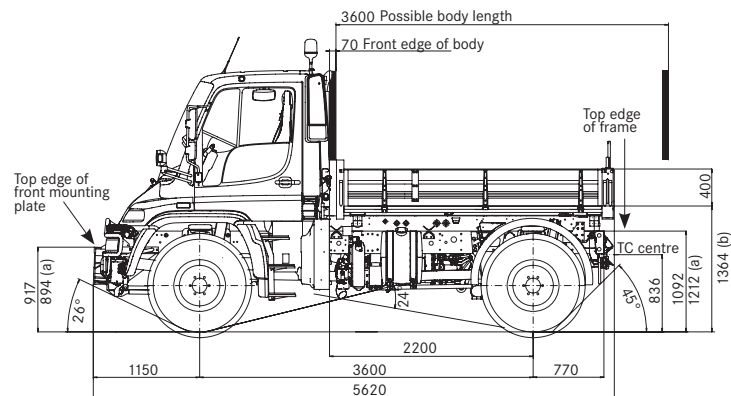
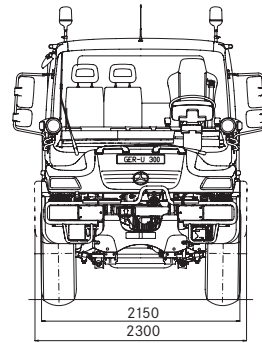

Wheelbase 3,600 mm (model variant 405.121)

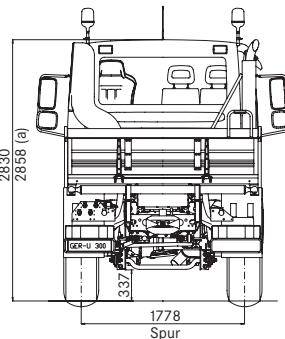

All dimensions in mm, shown with 365/80 R 20 tyres, (a) unladen, (b) with low platform intermediate frame, TC = trailer coupling

More information on the Mercedes-Benz Unimog can be found online at: [www.mercedes-benz.com/unimog](http://www.mercedes-benz.com/unimog)  
Daimler AG, Special Trucks Division, 76742 Wörth, Germany, 6703.T0200/Euro 5-02-00/0609  
The manufacturer reserves the right to make changes without notice. Printed in Federal Republic of Germany.

### Standard equipment

#### Engine

- Turbocharger, intercooler • 2 control characteristics (driving/implement mode) • Manual throttle (electronic) • Hydrostatic fan drive • Euro 5 emissions standard • 2-stage engine brake (constantly open throttle/throttle valve) • Air compressor 310 l/min • Air dryer • Air filter, moisture separator • Starter lock
- Cold start down to -16°C • Maintenance intervals every 30,000 km (1,200 operating hours)

#### Clutch/transmission

- Single-plate dry clutch, self-adjusting • 8 forward and 6 reverse gears • Permanent all-wheel drive with lockable interaxle differential • Telligent® gearshift • Cruise control/speed limiter • Max. speed limiter 90 km/h • EQR (Electronic Quick Reverse)

#### Frame/axes

- Continuous, rigid ladder-type frame • Front towing jaw with pin • Integral subframe for front mounting plate • Coil springs with progressive characteristic line • Front/rear stabilisers • Telescopic shock absorbers • Portal axles,  $i = 6.53$  • Differential lock at the rear • Anti-corrosion underbody protection (Dinol)

#### Cab, exterior

- Panoramic cab, seat position behind the front axle
- Short front end dimensions • Cab made out of corrosion-free, fibre-reinforced plastic • Cab strength acc. to ECE R29/2 • Comfort mounting with vibration damping • Tilting cab • Deep-set laminated windscreen • Deep-sill windows in the doors • Large rear window • Tinted glass all-round • Power windows • Windscreen washer system • 3-speed windscreen wipers with intermittent setting • Raised air intake
- Non-slip steps with grab handle • Heated exterior mirrors, electrically adjustable

#### Cab, interior

- Air conditioning system with heating and ventilation system, residual engine heat utilisation • Level cab floor • Stowage compartments and stowage box
- Overhead console with 2 installation openings for radio/tachograph • 3 sun visors • Centre console with central controls and 2 installation openings
- Combination switch on the steering column • Instrument cluster with analogue and LCD displays
- On-board diagnostics • Hour meter • Seats with tailored backrest and integral head restraint • Seats adjustable for height, length and angle, adjustable backrest, integral 3-point seat belts • Armrest in door trim • Interior lighting with reading lamps for driver and passengers • 3 coat hooks • Vehicle tools

#### Electrical system/lighting

- 24 V vehicle power supply • Electronics box protected in the cab • 24 V outlet • CAN bus network • Rear trailer socket, 15-pin • Battery 115 Ah • Electronic vehicle management system • EMC-certified
- Three-phase generator 28 V/100 A • Free-form headlamps • Headlamp range adjustment • Rear fog lamp • Reversing lights • End-outline marker lamps
- Additional indicators

#### Braking system

- Pneumatic/hydraulic high-pressure braking system (18 bar) • Disc brakes on all 4 wheels • 3-channel ABS, can be deactivated off-road • Automatic load-sensitive brake pressure control (ALB) • Compressed air connection for auxiliary loads • Spring-loaded parking brake • Tyre inflation connection • Brake pad wear indicator

In addition to this extensive standard equipment, we can also offer you a host of optional equipment and accessories to meet the specific operational needs of your Unimog. Your Unimog Partner will be happy to advise you.

Engines	110 kW (150 hp)	130 kW (177 hp)
Emissions class	Euro 5	Euro 5
Model	OM 904 LA	OM 904 LA
Type	4-stroke diesel direct injection with turbocharger/intercooler	
No. of cylinders/arrangement	4, in-line	4, in-line
Displacement	cc	4,250
Max. output	kW (hp)	110 (150)
at rated engine speed	rpm	2,200
Max. torque	Nm	610
Cooling system	Water with thermostat, hydrostatic fan drive	
Diesel fuel tank	Net capacity (litres)	135 (opt. 190)
AdBlue tank	Net capacity (litres)	25

## Transmission

- MB full-synchromesh reversing transmission with 8 forward and 6 reverse gears
- Opt. additional 8 fully loadable working gears and 8 crawler gears
- Opt. electronic AutomaticShift system
- Opt. hydrostatic drive, module operation

## Speeds (in km/h, forward)

Main gears	6.6	-	85.7
Working gears	1.1	-	14.9
Crawler gears	0.12	-	1.54

with 315/80 R 22.5 tyres and final drive ratio  $i = 6.53$

## Electrical system 24 V

- Battery 2 x 12 V/115 Ah, opt. 135 Ah
- Opt. 24 V/25 A and 12 V/15 A outlets with C3 signals
- Opt. 24 V/40 A equipment socket, 24-pin with C3/C4 signals

## Steering

- Hydraulic power steering, type: LS 6
- Opt. right-hand drive
- Opt. VarioPilot® transferable steering system
- Turning circle Ø short wheelbase from 13.7 m
- Turning circle Ø long wheelbase from 15.4 m

## Axles/drive

- Front/rear portal axles on trailing links and wishbones
- Opt. differential lock at front axle
- All locks can be selected and deactivated electro-pneumatically while in motion using a dog clutch (100% locking factor)

## Cab

### Exterior

- Optimum all-round visibility for working with implements • Opt. hydraulic tilt cab • Opt. heated windscreen • Opt. mowing door instead of right-hand door • Opt. vertical exhaust pipe

### Interior

- **Seats** • Opt. driver and passenger seats as heated, air-sprung luxury suspension seat • Opt. passenger seat as two-seater version; provides 3 seats with integral seat belts • Opt. swivel seat in conjunction with the mowing door on the passenger side
- **Air conditioning** • Opt. pollen filter • Opt. auxiliary heating with engine preheating, 7-day timer
- **Instruments, controls** • Driver information system (FIS) with status displays, event reports and menu-driven on-board diagnostics • 2-line indicator lamps, visual and acoustic warning indicators • Opt. digital tachograph

- **Safety** • Safety locks in the doors, steering and ignition lock • Opt. electronic immobiliser

## Lighting

- Opt. auxiliary headlamps with indicator lamps for implement operation • Opt. rear floodlight • Opt. rotating beacons

## Wheels/tyres

- 4 identical size tyres; single tyres
- Opt. low-pressure tyres with truck/AS/MPT treads
- Standard tyres 335/80 R 20
- Smallest tyres 335/80 R 20
- Largest tyres 425/75 R 20

## Max. permissible loads (in tonnes up to)

Perm. GVW	Front	Rear
7.5	4.6	4.6
8.5	4.6	4.6
9.5	5.1	5.5
10.2	5.1	5.5 subject to regulations

## Towing capacity

- Opt. dual-line trailer braking system
- As truck up to 15.3 t, with centre axle trailer up to 13 t
- As tractor up to 24 t, with centre axle trailer up to 13 t

## Hydraulics (optional)

### Working or common hydraulics

- acc. to EN 15431 for positioning movements and continuous loads (supplied as hydraulic packages)
- Single-circuit hydraulic system, with 48 l/min flow rate and 200 bar operating pressure
- Dual-circuit hydraulic system with proportional control, circuit I/II, with 24/48 l/min flow rate and 200/240 bar operating pressure
- Oil reservoir 45 l (consumption quantity 10 l)
- Circuit I controlled via 2 to 4 double-acting valves with floating position
- Up to max. 4 cells operated via joystick and switch, flow rate selection, flow summation

- Snowplough load relief to reduce the contact pressure when clearing snow
- Tipping cylinder with isolating valve and connections at the rear

## Power hydraulics

- for continuous loads demanding high power
- Circuit III (closed circuit) from 0 to 125 l/min flow rate and 300 bar operating pressure
- Circuit IV (open circuit) from 0 to 90 l/min flow rate and 280 bar operating pressure
- Circuit III and IV operating in tandem

## Auxiliary drives (optional)

### PTO shaft at the front

- Direct, mechanical power take-off from the engine drive train, power-shiftable, standard speed 540/1,000 rpm
- Rotates clockwise in the direction of travel
- Continuous output 150 kW
- Profile 1¾ inch, splined shaft

## Transmission-mounted auxiliary drive

- Mechanical transmission-mounted auxiliary drive to power hydraulic pumps
- High-speed PTO with  $i = 1.0$   
Speed 2,200 rpm, rotates anticlockwise in the direction of travel  
Max. torque 650 Nm  
Max. output 150 kW

## Implements and attachments (optional)

- Opt. front mounting plate acc. to DIN EN 15432, type F1c or acc. to DIN 76 060, type B, size 3
- Opt. frame attachment fittings/brackets, centre, rear and between the axles
- Opt. 3-sided tipper platform

opt. = optional