

## Mercedes-Benz Unimog U 4000 Euro 5

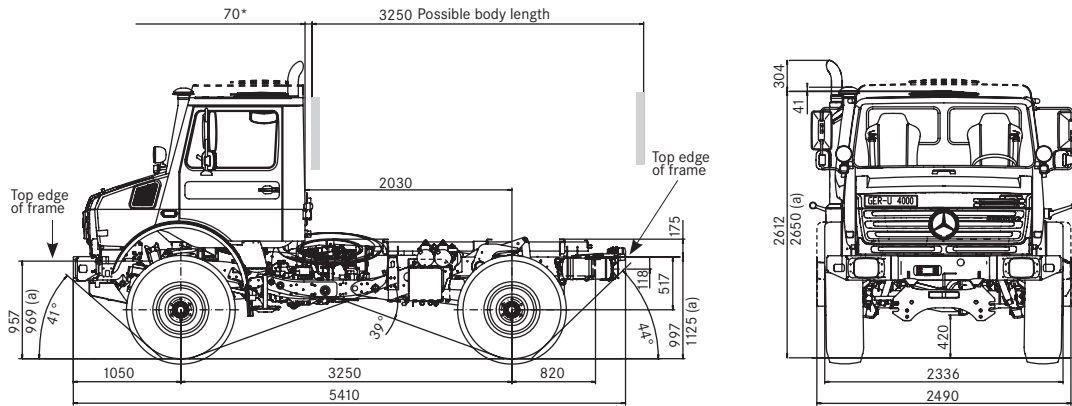

Wheelbase 3,250 mm (model variant 437.421) as chassis

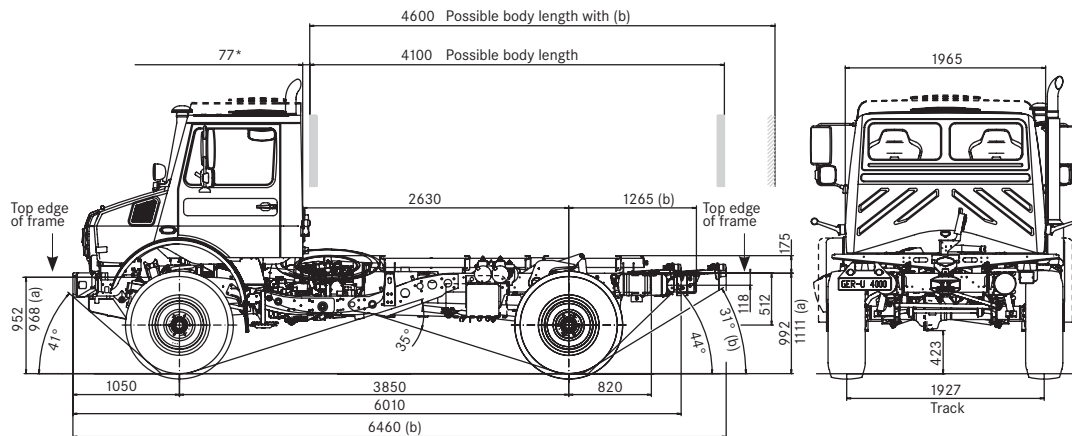

Wheelbase 3,850 mm (model variant 437.426) as chassis

All dimensions in mm, shown with 335/80 R 20 tyres, (a) unladen, (b) = frame extension, \* front edge of body

More information on the Mercedes-Benz Unimog can be found online at: [www.mercedes-benz.com/unimog](http://www.mercedes-benz.com/unimog)  
 Daimler AG, Special Trucks Division, 76742 Wörth, Germany, 6703.T111/Euro 5-02-00/0609  
 The manufacturer reserves the right to make changes without notice. Printed in Federal Republic of Germany.

### Standard equipment

#### Engine

- Turbocharger, intercooler • 2 control characteristics (on-road/off-road) • Manual throttle (electronic)
- 2 viscous fans with V-belt drive • Euro 5 emissions standard • 2-stage engine brake (constantly open throttle/throttle valve) • Air compressor 310 l/min
- Air dryer • Air filter, moisture separator • Cold start down to  $-18^{\circ}\text{C}$  • Maintenance intervals every 30,000 km (1,200 operating hours)

#### Clutch/transmission

- Single-plate dry clutch, self-adjusting • 8 forward and 6 reverse gears • Rear-axle drive with pneumatically selectable all-wheel drive • Telligent<sup>®</sup> gearshift
- Cruise control/speed limiter • Max. speed limiter 90 km/h • EQR (Electronic Quick Reverse)

#### Frame/axles

- Flexible, ladder-type frame with high torsional flexibility • 3-point mountings for engine, transmission
- Front towing jaw with pin • Coil springs with progressive characteristic line • Front/rear stabilisers
- Portal axles with hub drive,  $i = 6.53$  • Front/rear differential lock • Anti-corrosion underbody protection (Dinol)

#### Cab, exterior

- All-steel short-bonnet cab, roof flap • Seat position behind the front axle • Short front end dimensions
- Cab strength acc. to ECE R29/2 • Bonnet tilts for maintenance • 3-point sprung-mounted cab with dampers • High, protected windscreen • 2 rear windows • Tinted glass all-round • Power windows
- Windscreen washer system • Windscreen wipers with several speed settings and intermittent setting
- Dust-free air intake at cab roof height • Non-slip steps with grab handle • Heated exterior mirrors, electrically adjustable

#### Cab, interior

- Heating and ventilation system, 3-speed blower, residual engine heat utilisation • Rest table and stowage compartments • Overhead console with 2 installation openings for radio/tachograph • Up to 3 sun visors • Centre console with central controls, 1 installation opening • Combination switch on the steering column • Instrument cluster with analogue and LCD displays • On-board diagnostics • Hour meter • Seats with tailored backrest and integral head restraint • Driver's seat adjustable for height and length, adjustable backrest • 3-point seat belts all-round • Armrest in door trim • Interior lighting
- Coat hook • Vehicle tools

#### Electrical system/lighting

- 24 V vehicle power supply • Electronics box protected in the cab • 24 V outlet • CAN bus network
- Rear trailer socket, 15-pin • Battery 66 Ah • Electronic vehicle management system • EMC-certified • Three-phase generator 28 V/100 A • Halogen headlamps • Headlamp range adjustment • Rear fog lamp • Reversing lights • End-outline marker lamps
- Additional indicators

#### Braking system

- Pneumatic/hydraulic high-pressure braking system (18 bar) • Disc brakes on all 4 wheels • 4-channel ABS, can be deactivated off-road • Automatic load-sensitive brake pressure control (ALB) • Compressed air connection for auxiliary loads • Spring-loaded parking brake • Tyre inflation connection • Brake pad wear indicator • Air dryer

In addition to this extensive standard equipment, we can also offer you a host of optional equipment and accessories to meet the specific operational needs of your Unimog. Your Unimog Partner will be happy to advise you.

Engines	130 kW (177 hp)	160 kW (218 hp)
Emissions class	Euro 5	Euro 5
Model	OM 904 LA	OM 924 LA
Type	4-stroke diesel direct injection with turbocharger/intercooler	
No. of cylinders/arrangement	4, in-line	4, in-line
Displacement	cc	4,250
Max. output	kW (hp)	130 (177)
at rated engine speed	rpm	2,200
Max. torque	Nm	675
Cooling system	Water with thermostat, 2 viscous fans with V-belt drive	
Diesel fuel tank	Net capacity (litres)	145, with crewcab 160
AdBlue tank	Net capacity (litres)	18

## Transmission

- MB full-synchromesh reversing transmission with 8 forward and 6 reverse gears
- Opt. additional 8 fully loadable working gears/off-road gears
- Opt. electronic AutomaticShift system

## Speeds (in km/h, forward)

Main gears	6.6	-	85.7
Working gears	1.1	-	14.9

with 335/80 R 20 tyres and final drive ratio  $i = 6.53$

## Electrical system 24 V

- Opt. battery 2 x 12 V/100 Ah, or 125 Ah
- Opt. 24 V/25 A and 12 V/15 A outlets with C3 signals
- Opt. 24 V/40 A equipment socket, 24-pin with C3/C4 signals

## Steering

- ZF Servocom hydraulic power steering, type 8095
- Opt. right-hand drive
- Turning circle  $\emptyset$  short wheelbase from 14.3 m
- Turning circle  $\emptyset$  long wheelbase from 16.2 m

## Axles/drive/frame

- Portal axles connected to the transmission with torque tubes
- Axle tube and differentials situated above wheel centre line, high ground clearance
- Standard-fit front/rear differential locks, all locks can be selected and deactivated electropneumatically while in motion using a dog clutch (100% locking factor)
- Standard fording capability up to 800 mm
- Opt. fording system up to 1,200 mm fording depth
- Opt. heat protection and mechanical protection for forest firefighting
- Opt. frame extension, body length up to 4,600 mm possible

## Cab

### Exterior

- Opt. crewcab for 7 persons • Opt. hydraulic tilt cab • Opt. heated windscreen • Opt. cab extended by 120 mm • Opt. cab roof raised by 120 mm • Opt. round roof hatch • Opt. vertical exhaust pipe

## Interior

### Seats

- Opt. driver and passenger seats as air-sprung luxury suspension seat • Opt. passengers seat as two-seater version; provides 3 seats • All seats with 3-point seat belts and head restraints

### Air conditioning

- Integral air conditioning system or roof-mounted air conditioning system (also for crewcab) • Opt. auxiliary heating with engine preheating, 7-day timer

### Instruments, controls

- Driver information system (FIS) with status displays, event reports and menu-driven on-board diagnostics
- 2-line indicator lamps, visual and acoustic warning indicators • Opt. digital tachograph

### Safety

Safety locks in the doors, steering and ignition lock

## Lighting

- Opt. auxiliary headlamps with indicator lamps for implement operation
- Opt. waterproof halogen fog lamps
- Opt. rotating beacons

## Wheels/tyres

- 4 identical size tyres; single tyres
- Opt. low-pressure tyres with MPT/AS treads
- Standard tyres 335/80 R 20
- Smallest tyres 335/80 R 20
- Largest tyres 425/75 R 20
- Opt. tyre pressure control system (tirecontrol) to adjust the tyre pressure to on-road/off-road

## Max. permissible loads (in tonnes up to)

Perm. GVW	Front	Rear
7.5	4.0	4.4
8.5	4.0	4.6
9.5	4.4	5.3
10.0	4.5	5.8 only for firefighting

## Towing capacity

- Opt. dual-line trailer braking system
- As truck up to 14.2t, with centre axle trailer up to 9t

## Hydraulics (optional)

Universal hydraulic system for positioning movements and continuous loads, implement manufacturer to supply req. valves

- Single-circuit hydraulic system, with 60 l/min flow rate and 240 bar operating pressure
- Oil reservoir: 25 l (consumption quantity: 8 l)
- Can be controlled by equipment provided by implement supplier
- 2 connectors front and rear

## Auxiliary drives (optional)

### Transmission-mounted auxiliary drive

Mechanical transmission-mounted auxiliary drive to power hydraulic pumps or similar

- High-speed PTO with  $i = 1.0$
- Speed 2,200 rpm, rotates anticlockwise in the direction of travel
- Max. torque 520 Nm
- Max. output 110 kW/120 kW depending on engine output

or

- Ultra-high-speed PTO with  $i = 0.61$
- Speed 3,606 rpm, rotates to the right in direction of travel
- Max. torque 320 Nm
- Max. output 110 kW/120 kW depending on engine output

## Implements and attachments (optional)

- Front mounting plate acc. to DIN 76 060, type B, size 3
- Frame attachment fittings/brackets, front and centre; cable winch bracket
- Floor assembly with twin 3-point cab mountings